

POWER MANAGEMENT

Description

The SC4431 is a four terminal device for regulating an isolated power supply with output voltages down to 1.5V.

It is intended to be used as a replacement for three terminal shunt regulators such as SC431L where the output voltage is too low for the device to function in conjunction with an opto-isolator. SC4431 achieves this by having separate supply and output pins, allowing the output to sink current at voltages as low as 0.1V, while the supply pin still has sufficient voltage for the device to function. In this way, allowing for a 1.4V drop through an opto-isolator diode, regulation down to 1.5V out can be achieved.

The SC4431 shunt regulator is available with three initial reference voltage accuracies (0.5%, 1.0% and 2.0%) in the space saving 5-lead SOT-23 package. The three voltage tolerances allow the designer the opportunity to select the proper cost/tolerance for their application.

Lead free, fully WEEE and ROHS compliant

Features

- ◆ Open Collector output drives Optoisolator with as little as 1.5V input voltage
- ◆ Trimmed bandgap design - initial accuracies to $\pm 0.5\%$
- ◆ 40mA drive capability
- ◆ Regulates output as low as 50mV
- ◆ Wide supply voltage range - 1.5V to 15V
- ◆ Low supply current - typically 110 μ A
- ◆ Full industrial temperature range
- ◆ SOT-23-5 package

Applications

- ◆ Telecom Power Supplies
- ◆ Opto driver for very low output voltage (1.5V) isolated power supplies
- ◆ Battery operated applications
- ◆ Point of use power supplies

Typical Application Circuit

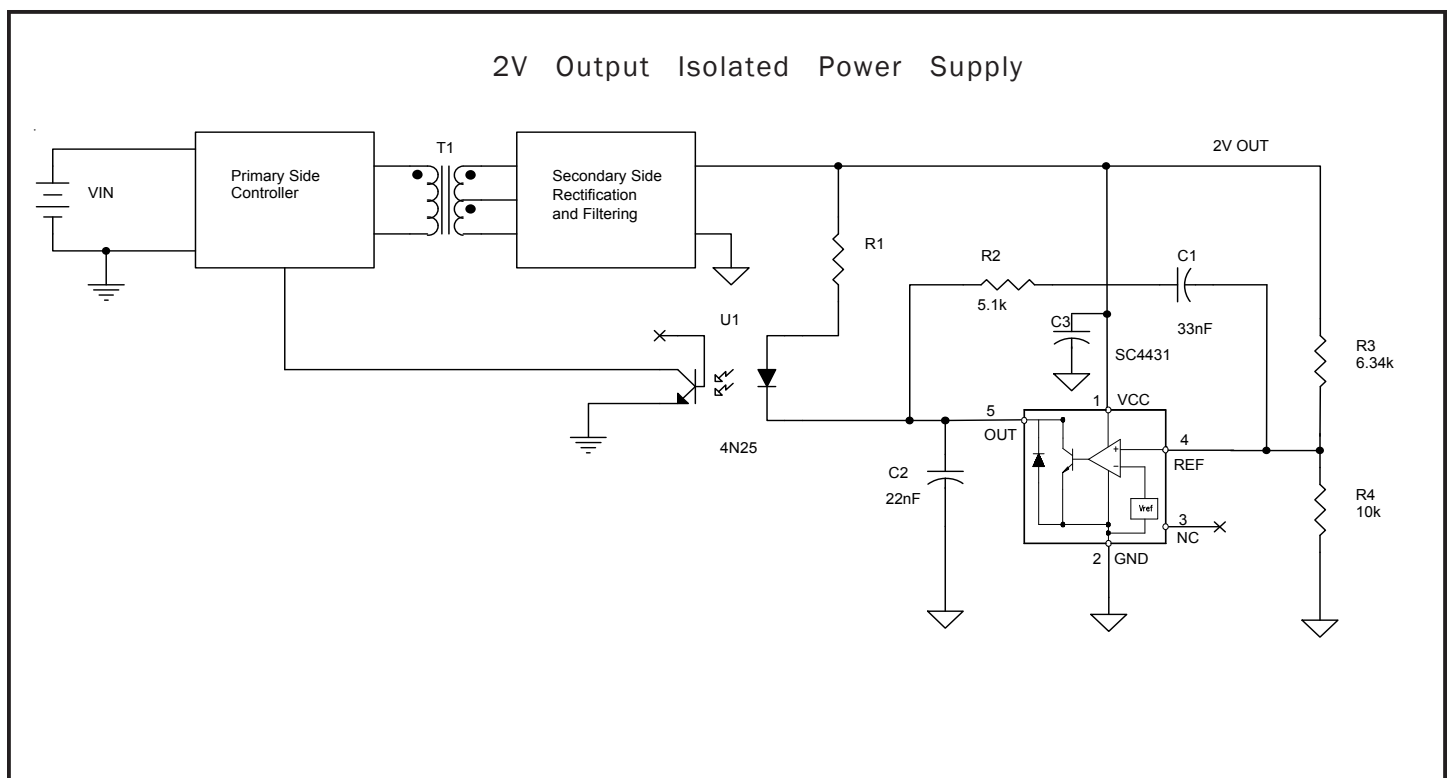

POWER MANAGEMENT

Absolute Maximum Rating

Parameter	Symbol	Maximum	Units
Input Supply Voltage	V_{CC}	-0.5 to +16	V
Vcc pin current	I_{CC}	8	mA
Output Voltage	V_{OUT}	-0.5 to VCC	V
Reference Voltage ⁽¹⁾	V_{REF}	-0.5 to +4	V
Continuous Output Current	I_{OUT}	40	mA
Reference Input Current	I_{REF}	5	mA
Operating Ambient Temperature Range	T_A	-40 to +85	°C
Operating Junction Temperature Range	T_J	-40 to +150	°C
Storage Temperature Range	T_{STG}	-65 to +150	°C
Thermal Impedance Junction to Ambient	θ_{JA}	256	°C/W
Thermal Impedance Junction to Case	θ_{JC}	81	°C/W
Power Dissipation at $T_A = 25^\circ\text{C}$	P_D	475	mW
Lead Temperature (Soldering) 10 seconds	T_{LEAD}	300	°C
ESD Rating (Human Body Model)	ESD	2	kV

(1) If Vref will be forced above 1.224V, a resistor must be placed in series with the Vcc to limit the Icc current below 5mA.

Electrical Characteristics

Unless specified, $T_A = 25^\circ\text{C}$, $V_{CC} = 2\text{V}$, $I_{OUT} = 2\text{mA}$. Values in bold apply over full operating temperature range.						
Parameter	Symbol	Test Conditions	MIN	TYP	MAX	Units
VCC						
Input Supply Voltage	V_{CC}		1.5		15	V
Input Supply Current	I_{CC}	$V_{REF} = V_{OUT}$		110	200	μA
Off State Input Supply Current	$I_{CC(OFF)}$	$V_{REF} = 1.187\text{V}$, $V_{OUT} = 2\text{V}$		65	100	μA
					150	
REF						
Reference Voltage	V_{REF}	SC4431-.5, $V_{REF} = V_{OUT}$	1.219	1.224	1.231	V
			1.207		1.243	
		SC4431-1, $V_{REF} = V_{OUT}$	1.212	1.224	1.236	V
			1.200		1.250	
		SC4431-2, $V_{REF} = V_{OUT}$	1.200	1.224	1.250	V
			1.187		1.261	
Change in V_{REF} due to change in V_{CC}	dV_{REF}/dV_{CC}	$V_{CC} = 1.5\text{V to }15\text{V}$		8	15	mV
					20	
Change in V_{REF} due to change in I_{OUT}	dV_{REF}/dI_{OUT}	$I_{OUT} = 0.1\text{mA to }40\text{mA}$		8	28	mV
					36	
Reference Input Current	I_{REF}	$0.1\text{mA} \leq I_{OUT} \leq 10\text{mA}$		0.3	0.5	μA
					1.0	
OUT						
Saturation Voltage	$V_{OUT(SAT)}$	$I_{OUT} = 5\text{mA}$, $I_{CC} = 500\mu\text{A}$		50	75	mV
					100	
		$V_{REF} = 1.261\text{V}$, $I_{OUT} = 32\text{mA}$		275	300	mV
					400	
Off State Output Current	$I_{OUT(OFF)}$	$V_{REF} = 1.187\text{V}$, $V_{OUT} = 2\text{V}$		0.50	1	μA
					10	

POWER MANAGEMENT

Pin Configurations

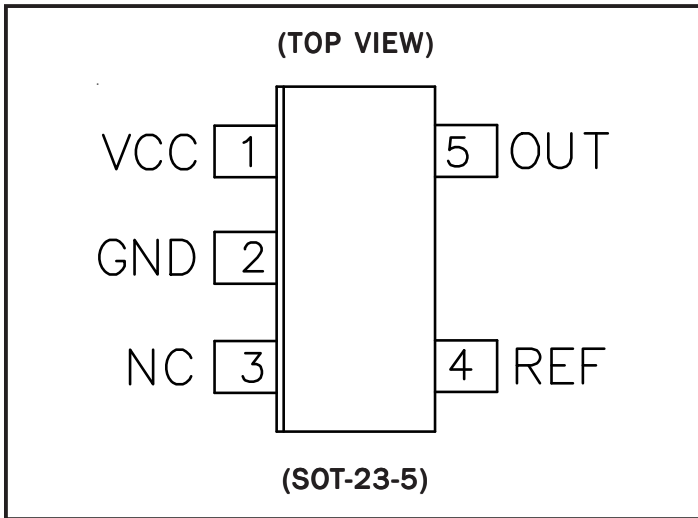

Ordering Information

Part Number ⁽¹⁾⁽²⁾	Package
SC4431CSK-X	SOT-23-5

Notes: (1) Only available in tape and reel packaging. (Suffix '.TRT' e.g. SC4431CSK-X.TRT).
 (2) Where "-X" denotes initial reference voltage tolerance. Available options are $\pm 0.5\%$ (-.5), $\pm 1\%$ (-1) and $\pm 2\%$ (-2).

Pin Descriptions

Pin#	Pin Name	Pin Function
1	VCC	This is the input supply pin for the SC4431. A low ESR capacitor should be used to bypass this pin to GND right at the IC.
2	GND	Logic and power ground.
3	NC	No connection.
4	REF	This is connected to the non-inverting input of the error amplifier.
5	OUT	This is the output pin of the device, essentially an open collector. Note: A 22nF low ESR (ceramic) capacitor is required from this pin to GND for stable operation.

Block Diagram

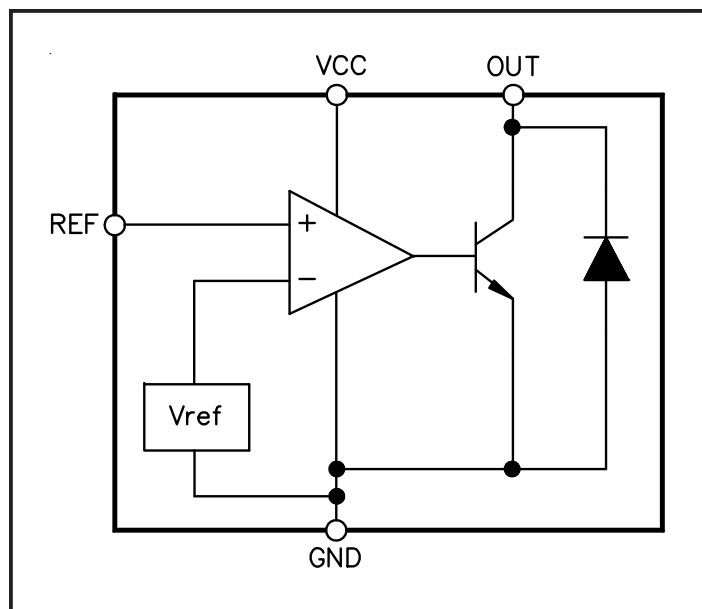

Marking Information

Top Mark

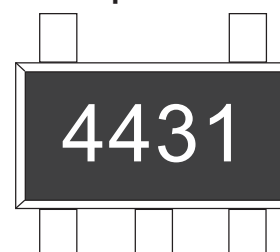

Bottom Mark

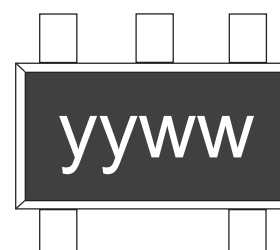

yyww = Datecode (Example: 9908)

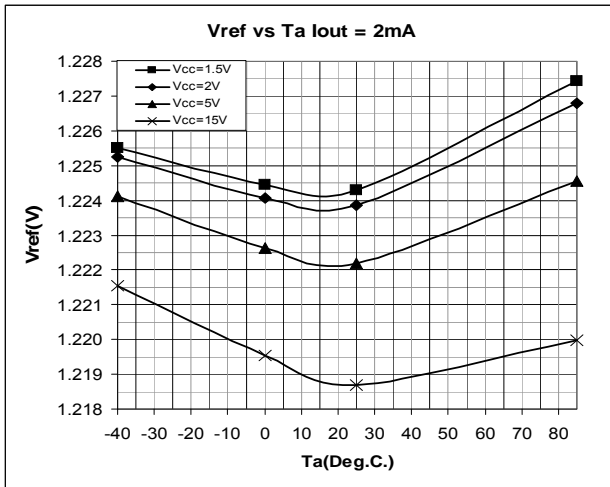

Typical Vref vs Ta Iout = 2mA

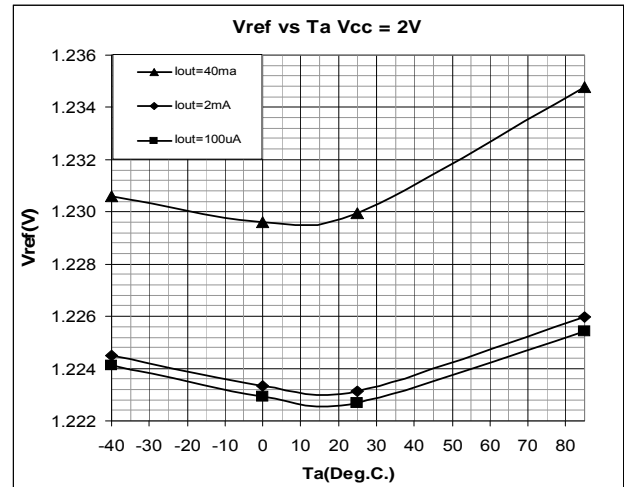

Typical Vref vs Ta Vcc = 2V

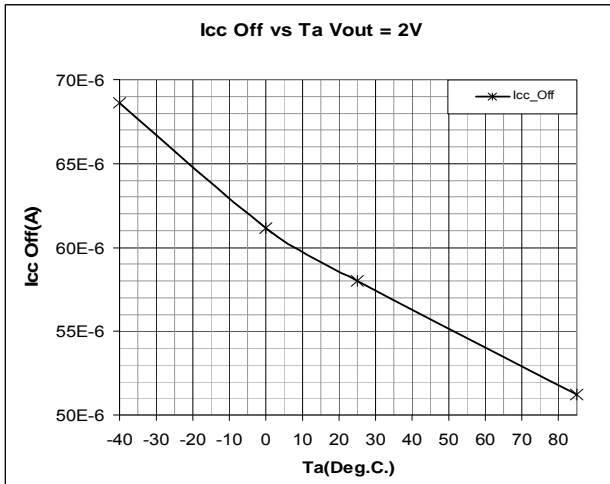

Typical Icc Off vs Ta Vout = 2V

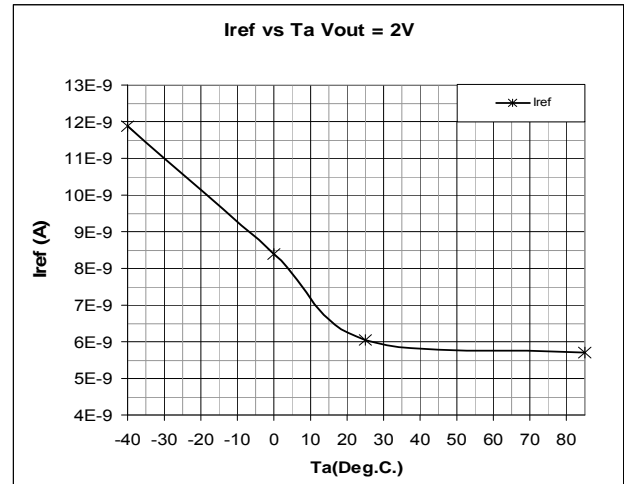

Typical Iref vs Ta Vout = 2V

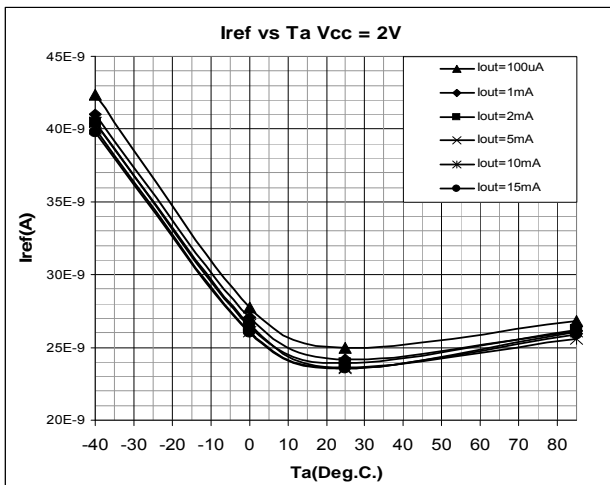

Typical Iref vs Ta Vcc = 2V

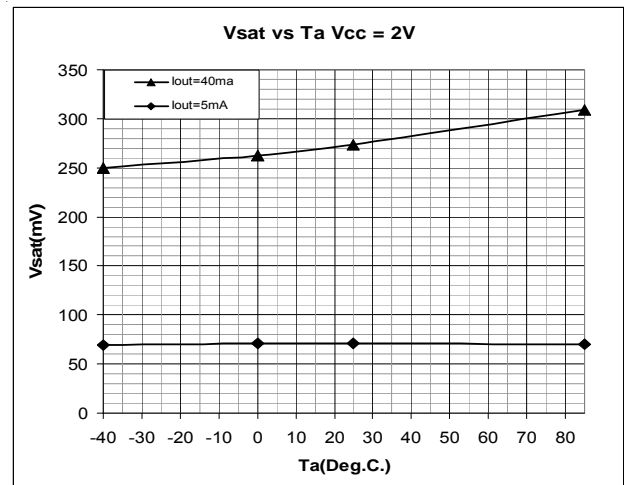

Typical Vsat vs Ta Vcc = 2V

POWER MANAGEMENT

Typical Characteristics

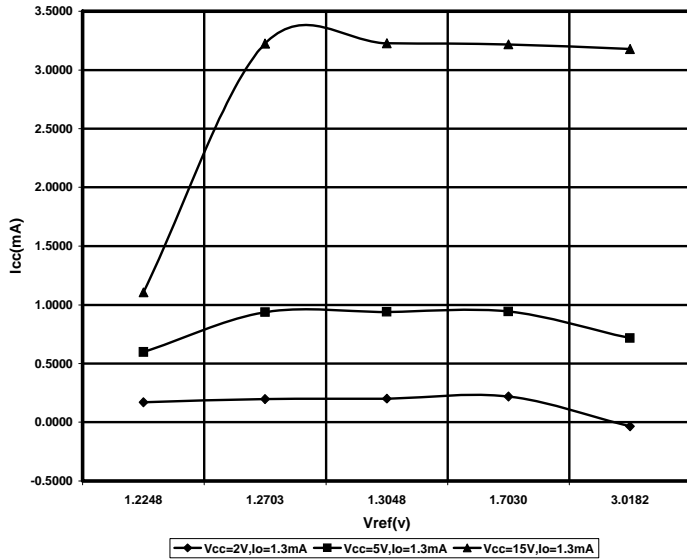

Typical Icc vs Vref, Io = 1.3mA, Ta = 25 Deg.C.

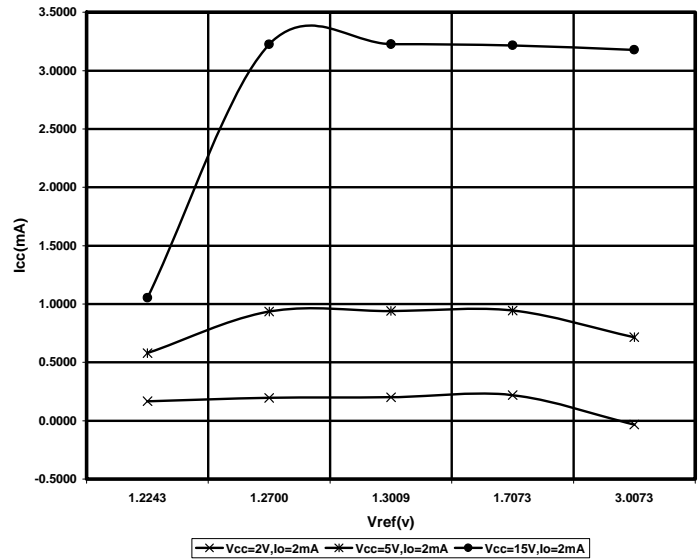

Typical Icc vs Vref, Io = 2mA, Ta = 25 Deg.C.

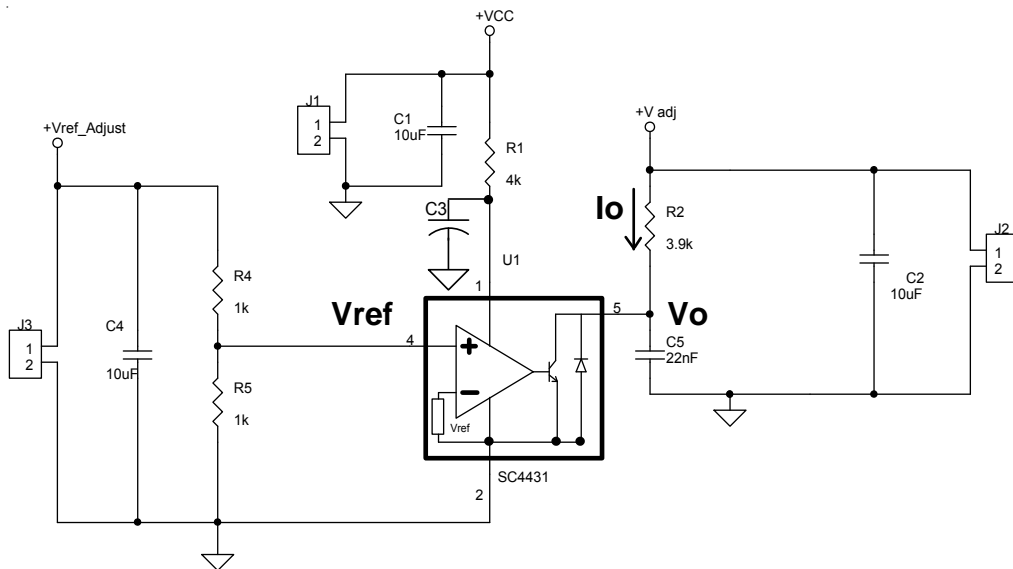

Icc vs Vref Test Circuit

Typical Gain Phase

SC4431 Gain / Phase Vin = 2V, Iout = 2mA, Vout = 1.6V

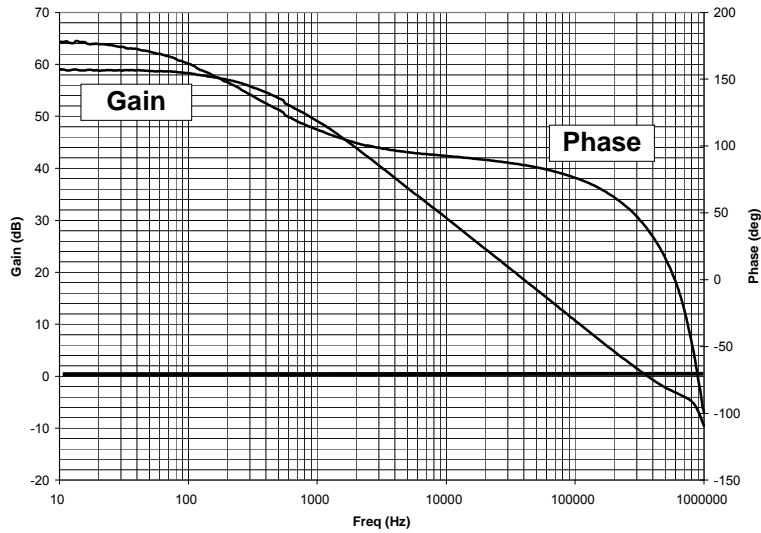

SC4431 Gain / Phase Vin = 4V, Iout = 2mA, Vout = 2V

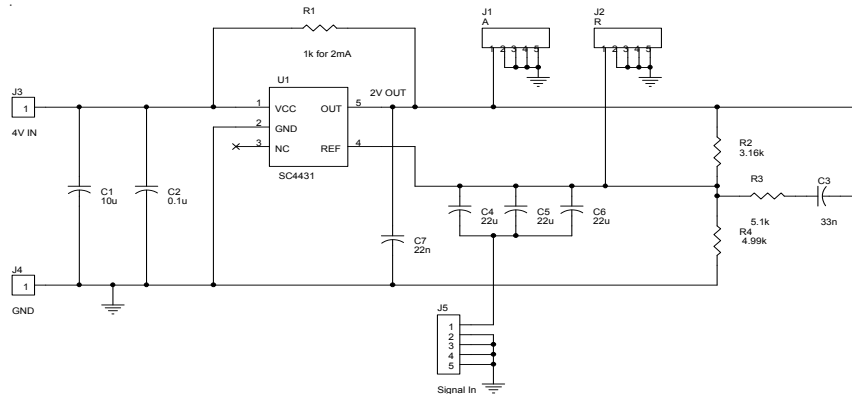
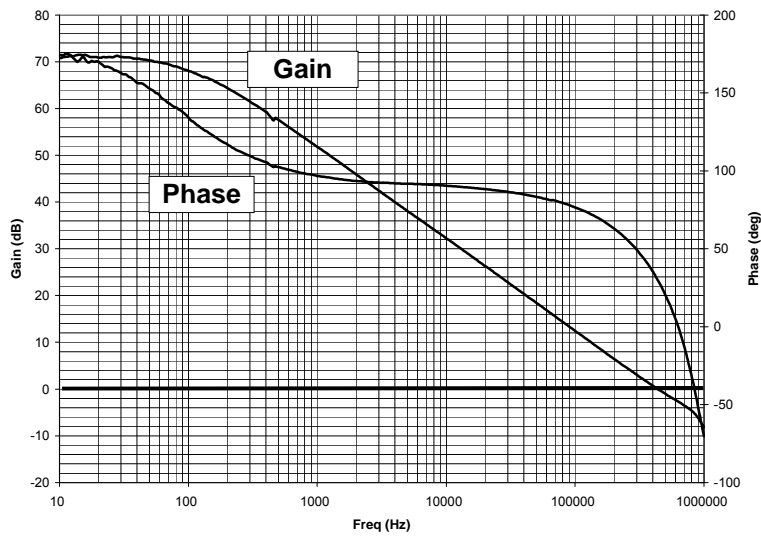

Gain Phase Test Circuit

POWER MANAGEMENT

Typical Applications

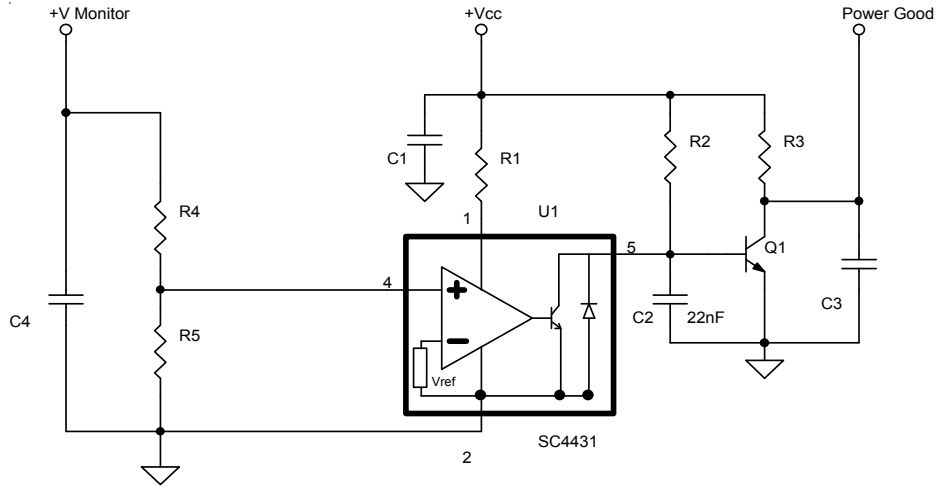

Power good Circuit

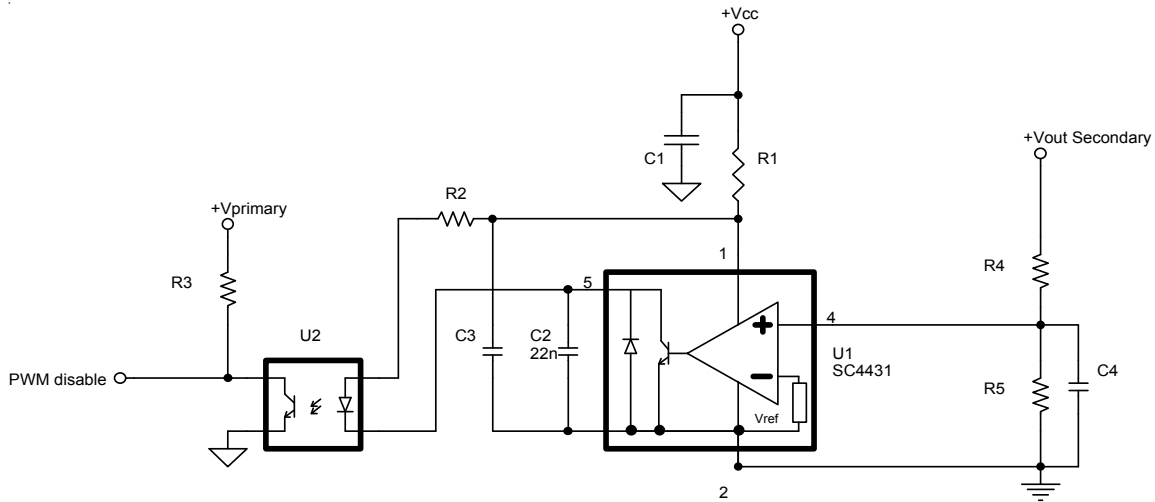

Isolated OVP Circuit

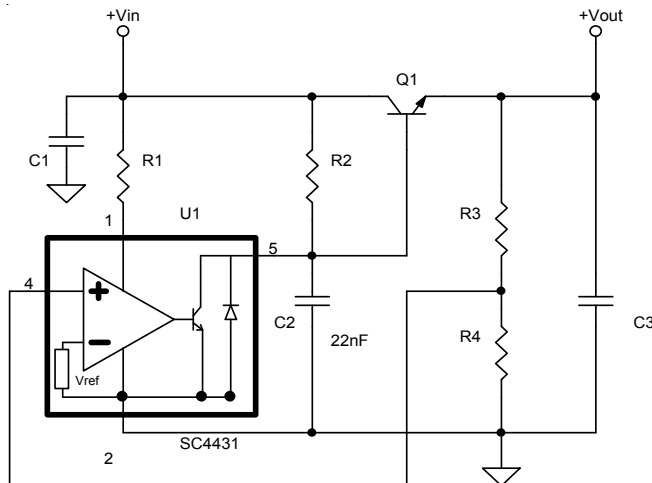

Linear Regulator Circuit